

LET US
enlighten
YOUR FIBRE
NETWORKS



ONU Mounting and Protection - TEN-FWO14

enlighten ONU Mounting Plate

This mounting plate is designed to provide a secure fixing point for different sizes of ONU to be mounted onto the walls inside a property. It also provides support for incoming cable management and fibre splicing, all held discretely under a cover which forms the basis to mount the ONU on to. The mounting plate is designed to fit over existing wall mounting boxes and use the same fixing centres to attach this mounting plate in place of the existing wall box cover.

Features

- Secure ONU mounting onto a wall.
- Supports different size ONU's.
- Multiple ONU securing points.
- Incoming fibre cable management and spare coiling.
- Fibre splice holder position.
- Single fibre adapter.
- Fits onto back box using same fixing positions.
- Replaces back box cover.

TELESTE

enlighten OPTICAL PASSIVES / ONU MOUNTING AND PROTECTION

GENERAL	
Style	To fit over existing UK single way flush wall back box (see info. beneath)
Dimensions (approx.)	Height – 135mm Width – 135mm Depth – to accommodate 1 x splice and 1 x SC/APC adapter
Customer Connection	1 x SC/APC
Mounting/Fixing	To use existing wall box fixing centres of 60.3mm (3.5mm screws) <u>Note:</u> metal and plastic versions of back box have same fixing centres
Splicing	Positions to splice 1 incoming fibre splice
Cable Entry Ports	1 in the base to bring a fibre cable through from back box. Size TBD
Material	Plastic Colour White
Cover	Clips onto Mounting Plate securely and support weight of ONT To have 2 sets of mounting feet 1 set fixing feet at 60mm centres 1 set fixing feet at 85mm centres

MECHANICAL LAYOUT

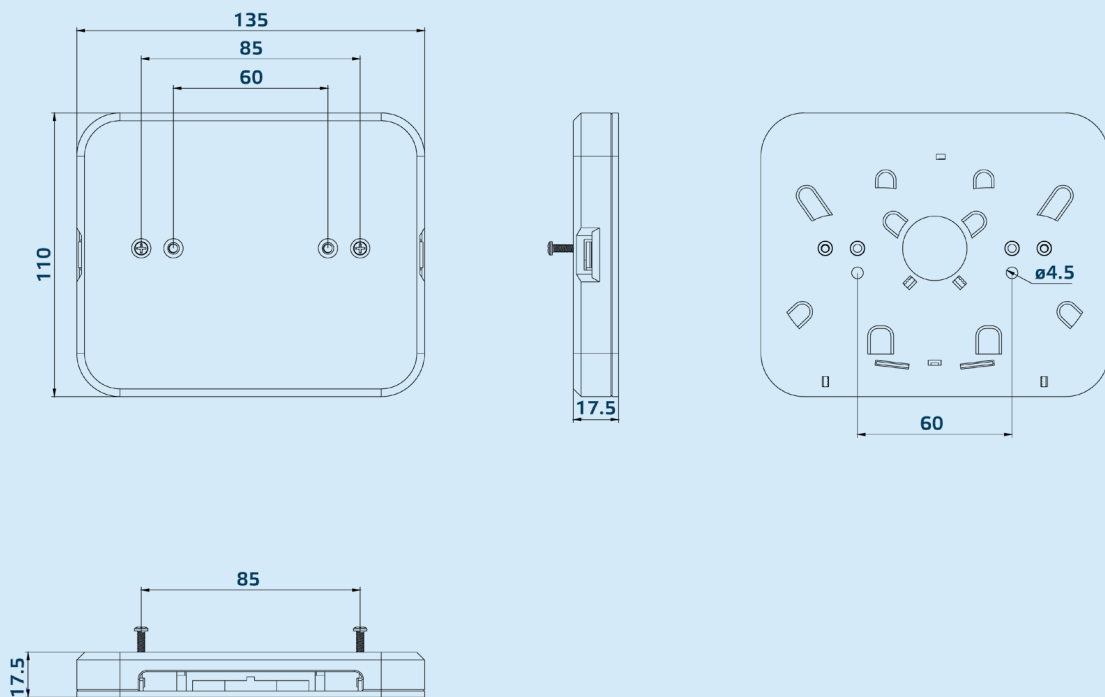

ORDERING INFORMATION

P/N	DESCRIPTION
TEN-FW014	ONU Mounting Plate - 1 x SC/APC Customer Connection



TELESTE CORPORATION

www.teleste.com

Enlighten ONU Mounting and Protection TEN-FW014_230516

Copyright © 2023 Teleste Corporation. All rights reserved. Teleste and the Teleste logo are registered trademarks of Teleste Corporation. Other product and service marks are property of their respective owners.

Teleste reserves the right to make changes to any features and specifications of the products without prior notice. Although the information in this document has been reproduced in good faith, the contents of this document are provided "as is". Teleste makes no warranties of any kind in relation to the accuracy, reliability or contents of this document, except as required by applicable law.