



AC Series

## AC1800 & AC2800

# 1.8 GHz BROADBAND AMPLIFIERS

The best upgrades do more than meet the next specification; they make the next decision easier. AC1800 and AC2800 combine high output, wide usable gain, native smart features and controlled power consumption in a compact platform built for European cabinets. Operators get a stronger active plant today, with 1.8 GHz downstream capability already in place — ready for immediate 1.8 GHz upgrades, or already tuned for the next move.

Whether the target is to move to DOCSIS® 4.0 as soon as possible or to stealthgrade towards 10 Gbit/s networks, the new AC Series is ready for the challenge — delivering both raw capacity and the superior QoS the next network step requires. Designed for European street cabinets, the AC Series combines high RF output, a wide gain range, compact mechanics, controlled power consumption and rugged outdoor reliability.

In Europe, the real test is whether the amplifier can deliver performance in a street cabinet, within the available space, power budget and thermal conditions. AC1800 and AC2800 were built to exceed expectations in that test. They bring 1.8 GHz downstream capability into a compact AC platform with controlled power consumption, robust mechanics and reliable operation across a wide temperature range. Operators can move the active network towards 1.8 GHz without turning amplifier renewal into a cabinet redesign.

**TELESTE**

# AC1800 & AC2800 AMPLIFIERS SMART FUNCTIONS AS STANDARD — NO TRANSPONDER REQUIRED

AC1800 and AC2800 include their key automatic control features as standard. Pilot-based Automatic Level and Slope Control, automatic return path alignment, Return Follows Forward and ingress control are native. The optional transponder adds remote communication and management access. The amplifier is smart by design; the transponder makes it remotely visible.

## Align at setup. Adjust during operation

AC1800 and AC2800 enable three distinct things clearly: local setup, automatic amplifier control and remote network access.

Technicians can configure the amplifier locally at the cabinet. Built-in automatic functions support alignment during setup and continuous adjustment during operation. The optional transponder is added only when the operator wants remote monitoring and control. This makes the operating model simple: automatic control is native; remote communication is optional., even technicians with minimal experience can quickly install each unit in the field, reducing downtime and simplifying daily operations.

## High output, controlled power

AC1800 and AC2800 provide up to 54 dB maximum gain and 70 dBmV Total Composite Power per active downstream output. AC1800 offers a compact single-active-output solution with typical power consumption of 28 W. AC2800 provides two active outputs, with an optional third output enabled by an output plug-in module, with typical power consumption of 45 W.

Power Save functionality lowers consumption further when enabled. For dense cabinet deployments, this means less heat generation, reduced power supply load and better use of existing cabinet infrastructure.

- **Wide temperature range:** Operation from -40...+60 °C supports reliable use in outdoor cabinet conditions.
- **Protected for access networks:** The IP67 enclosure, enhanced surge protection and robust RF design support stable operation in real outside-plant environments.

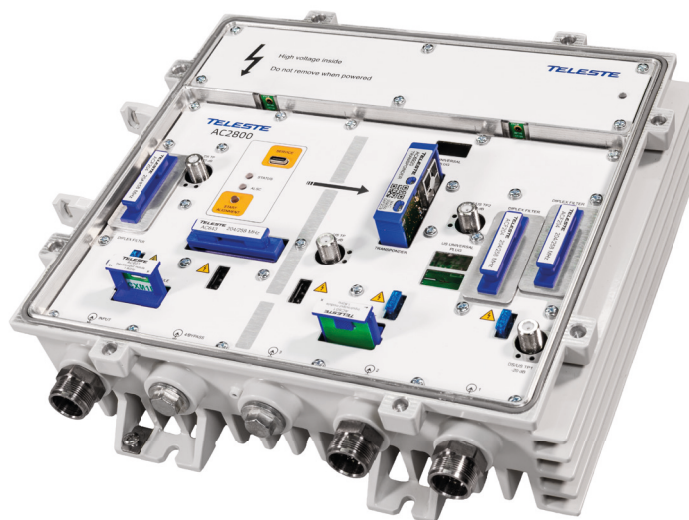

- **AC1800:** Single active output amplifier for compact, high-performance trunk and distribution applications.
- **AC2800:** Dual active output amplifier for sites requiring more output flexibility. An optional output plug-in module enables a third output when the network layout requires it.

*Cabinet-sized housing: The compact housing supports installations where available cabinet space is limited.*

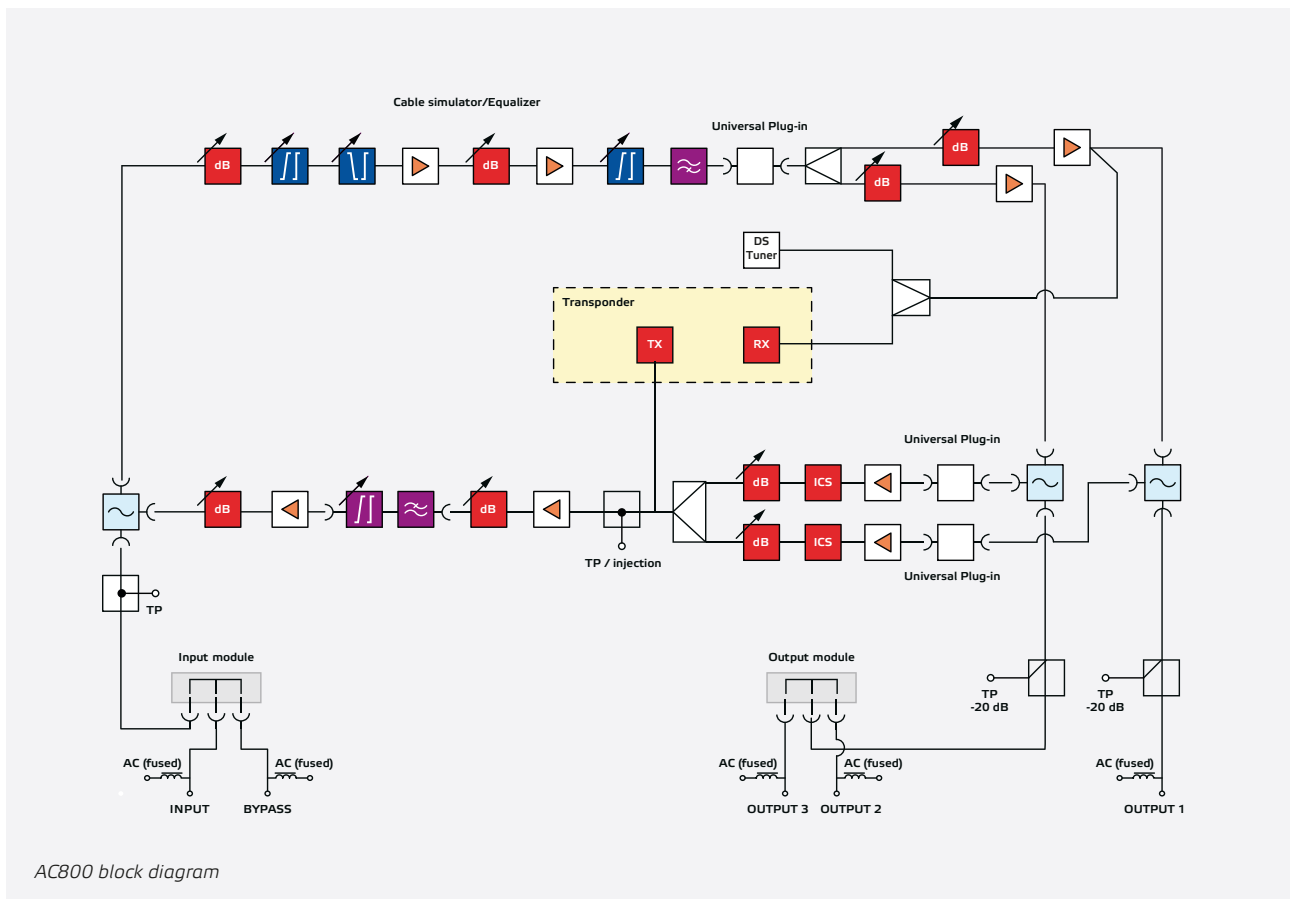

### GaN for output – GaAs for efficiency

The downstream path uses GaN technology for the high output and RF performance needed at 1.8 GHz. The return path uses GaAs technology. Together, they create a balanced amplifier architecture for networks operating today at 1.2 GHz or below, while placing 1.8 GHz headroom in the same installation.

### Advanced Features

**Automatic split detection:** The frequency split is changed with plug-in modules, and the amplifier detects the selected split automatically.

**Automatic return path alignment:** During setup, the return path can be aligned automatically. This helps technicians complete upstream configuration faster and with consistent results across sites.

**Automatic Level and Slope Control:** During operation, pilot-based ALSC keeps level and slope stable as network conditions change.

**Return Follows Forward:** During operation, RFF keeps return path adjustments linked to the forward path control state. The return path follows the amplifier's downstream control without manual correction.

**Ingress control:** Integrated ingress control switches help isolate return path noise and protect upstream performance.

**Fast local setup:** A built-in USB-C connector provides direct local configuration with a hand-held device. Wireless local configuration is also supported with a BT adapter. These local access options support fast installation, maintenance and troubleshooting at the cabinet.

**Remote visibility when needed:** For operators requiring centralized monitoring and control, AC1800 and AC2800 each include a slot for an optional transponder module. With the transponder installed, amplifier parameters can be accessed remotely for network management and troubleshooting.

**Stealthgrade the active plant:** AC1800 and AC2800 let operators install 1.8 GHz capability before a full 1.8 GHz service rollout is required. They can be deployed as powerful amplifiers for current 1.2 GHz and sub-1.2 GHz networks, while the 1.8 GHz downstream path is already present from day one. For networks already upgraded with 1.8 GHz passives, the active plant can now follow the same path without forcing the timing of the service migration.

## AC1800 & AC2800 / 1.8 GHZ BROADBAND AMPLIFIERS

DOWNSTREAM SIGNAL PATH			
Frequency range	105...1794 MHz	Input slope control	-24...24 dB
Return loss	18 dB	Interstage slope control	12...25 dB
Maximum gain	1 x 54 dB (AC1800)	Output level offset	0...10 dB
	2 x 54 dB (AC2800)	Flatness	±0.5 dB
Nominal gain	1 x 50 dB (AC1800)	Test point	-20 dB
	2 x 50 dB (AC2800)	Noise figure	10 dB
Gain control	14 ...54 dB	Max. TCP	2 x 70 dBmV
LEVEL MEASUREMENT UNIT: ALSC			
Forward path measurement range	138...1794 MHz	Dynamic range	20...60 dBmV
Measurement bandwidth	~1 MHz	Detection mode	Digital
Measurement inaccuracy	< 1.0 dB		
UPSTREAM SIGNAL PATH			
Frequency range	10...492 MHz	ICS	0/-6/-40 dB
Return loss	18 dB	Flatness	±0.5 dB
Maximum gain	32 dB	Test point	-10 dB
Gain control	12...32 dB	Noise figure	6 dB (AC1800)
Slope control	3...20 dB		10 dB (AC2800)
GENERAL CHARACTERISTICS			
Power consumption	28 W (AC1800)	Dimensions (H x W x D)	280 mm x 260 mm x 110 mm
	45 W (AC2800)	Weight	2.9 kg (AC1800)
Power supply voltage	30...90 VAC / 110...230 VAC		3.8 kg (AC2800)
Maximum current feed through	8 A/port	Temperature range	-40...+60 °C
Hum modulation	65 dB/port	Class of enclosure	IP67
AC current resistance	15 mΩ / port	Safety	UL/EN 62368-1, EN 60728-11
Test point connectors	F-female	EMC	EN 50083-2, EN 60728-2, FCC part 15
		ESD	4 kV
		Surge	6 kV, EN 60728-3, SCTE 81

# TELESTE

TELESTE CORPORATION  
[www.teleste.com](http://www.teleste.com)

P4P\_AC2800\_0526

Copyright © 2026 Teleste Corporation. All rights reserved. Teleste and the Teleste logo are registered trademarks of Teleste Corporation. Other product and service marks are property of their respective owners. Teleste reserves the right to make changes to any features and specifications of the products without prior notice. Although the information in this document has been reproduced in good faith, the contents of this document are provided "as is". Teleste makes no warranties of any kind in relation to the accuracy, reliability or contents of this document, except as required by applicable law.